

# International Trolley

## ASSEMBLY INSTRUCTIONS



Tools required: 1 adjustable spanner  
1 phillips head screwdriver

[www.lifestylebbqs.com](http://www.lifestylebbqs.com)

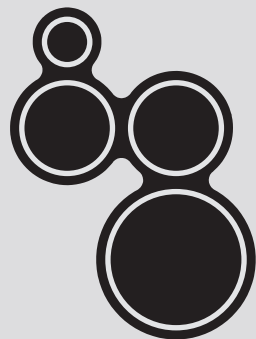

# Lifestyle

The Australian Barbeque

See [www.lifestylebbqs.com](http://www.lifestylebbqs.com) 'My New Lifestyle Barbeque' for updates, other instructions, recipes and other information to get the greatest enjoyment from your Lifestyle Barbeque.

# Trolley parts



front infill panel



door



door handle



2 x side panels



back panel



base panel



2 pairs side shelf brackets



cylinder bracket



found in separate carton:  
2 side shelves (if S/S KIT is ordered) or  
1 side shelf and 1 side burner (if S/B KIT is ordered.)



2 x large nylon washers



2 x rotating door supports



2 x rubber door stops



4 x long bolts



4 x 30mm screws



17 x 15mm screws



4 x small washers



4 x locking nuts



12 x 10mm screws



2 x 4mm 10mm small screws

Remove  
easiest  
then re  
trolley

Slot the  
the bo  
a long  
via ca

Hint:  
Hint:

3

Screw

# 1

Remove protective plastic film from all components. It is often easiest to remove the plastic from the mating surfaces only, then remove the remaining plastic when the barbecue and trolley are fully assembled.

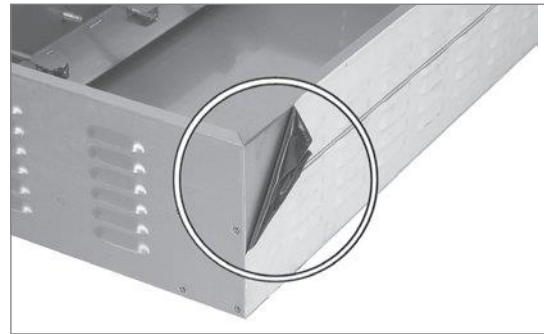

# 2

## YOU WILL NEED

4 x long screws



Slot the side panel tangs into the base panel. Secure using a long screw at each corner via castor

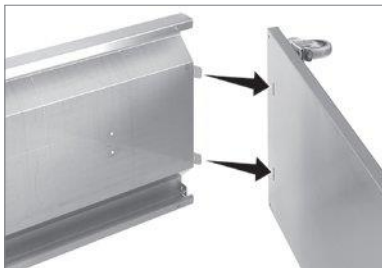
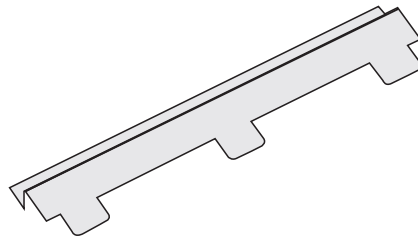

Base shelf is pictured with castors fitted. To assemble the base shelf first fit the castor adaptor plate.

Insert the tangs into the corresponding slots on the underside of the base shelf.

Then fit four castors via 3x15mm screws and 1x long bolt for each castor.

Be sure to carefully align the long screw and start the first few turns by hand before using a cordless drill. Lubricate the bolt and restart the thread if resistance is felt.

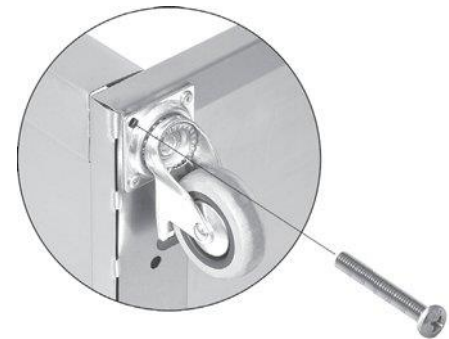

**Hint: It may be easier if most of your trolley assembly is done with the trolley on its back.**  
**Hint: Lubricate the screws to avoid them jamming in the nut sert**

# 3

## YOU WILL NEED

5 x 15mm screws



Screw the rear panel into place.

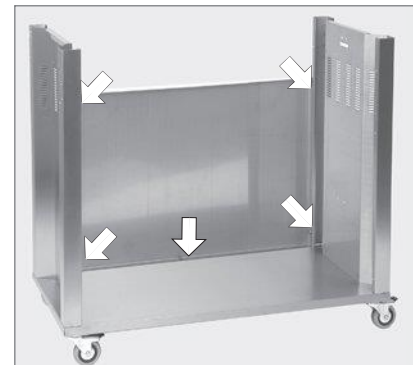

4

YOU WILL NEED

2 x 15mm screws

2 x locking nuts

2 x small washers

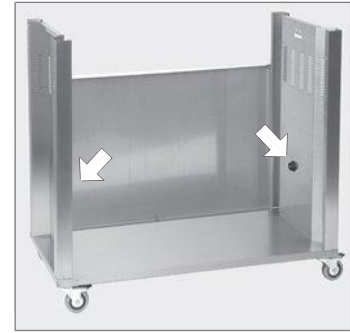

Peel the film and place the self-adhesive polyurethane door stops over the hole nearest the rear of the cabinet.  
Screw the door stops to each side panel as shown.



Screw panels toward door is bottom Use a the rot side p

5

YOU WILL NEED

4 x 10mm screws



Screw the rotating door supports to each side of the door.  
The flat face of the door support aligns with outer edge of the door.



Screw

6

YOU WILL NEED

2 x 4mm screws

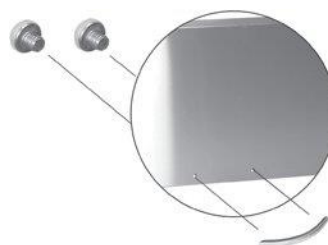

Screw the door handle to the door.

4

7

YOU WILL NEED

2 x 15mm screws

2 x locking nuts

2 large nylon washers



Screw the door supports to the side panels. Ensure the door handle is towards the front, so that when the door is closed, the handle is at the bottom of the trolley.

Use a large nylon washer between the rotating door supports and the side panel.



8

YOU WILL NEED

4 x 15mm screws



Screw in the front infi II panel.

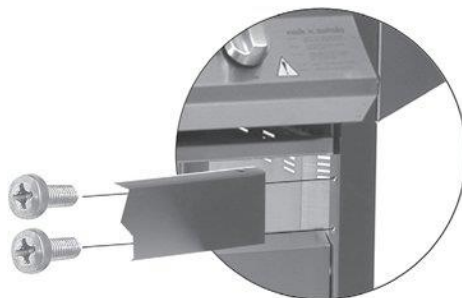

9

If you have a side burner, you will only need one plain side shelf, which is placed on the left hand side of the trolley.

If there is no side burner, repeat steps 9 and 10 for both sides of the trolley.



Slot the side shelf support tangs into the side shelf.



10

YOU WILL NEED

2 x 15mm screws

4 x 10mm (small) screws



Place the side shelf over the side panel so that the triangular side shelf supports sit neatly up against the side panel.



Use the 15mm screws to screw the tray of the side shelf into place. The screws go in through the side panels.



Screw the side shelf supports into the side panels. Use the top and bottom holes and 4 x 10mm screws for this purpose.

6

# 11

Side burner models only.

Slot the side shelf supports into the side burner, similarly to step 9.



# 12

YOU WILL NEED

2 x 15mm screws

4 x 10mm (small) screws



Attach the side burner to the right side of the trolley, similarly to the side shelf in step 10.



Place the side burner over the side panel so that the triangular side shelf supports sit neatly up against the side panel.



Use the 15mm screws to screw the body of the side burner into place. The screws go in through the side panels.



Screw the side shelf supports into the side panels. Use the top and bottom holes and 4 x 10mm screws for this purpose.

# 13

## YOU WILL NEED

4 x 30mm screws



1 x 19mm dia washer



Slide the barbeque body into position (again, it may be easier to do this with the trolley on its back).

Secure with 4 x 30mm screws as shown.

The longest Phillips head screwdriver you have will make this task easier.

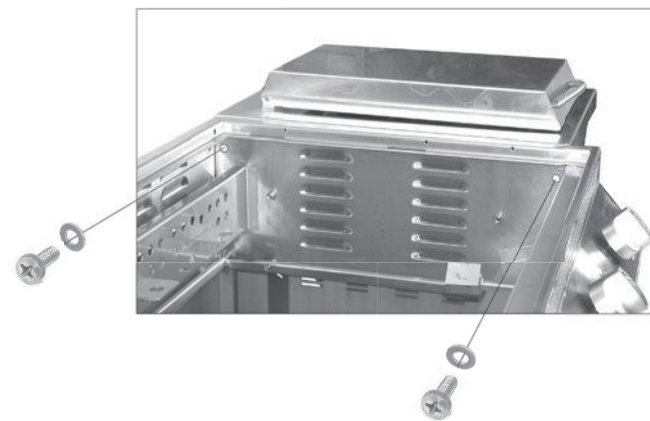
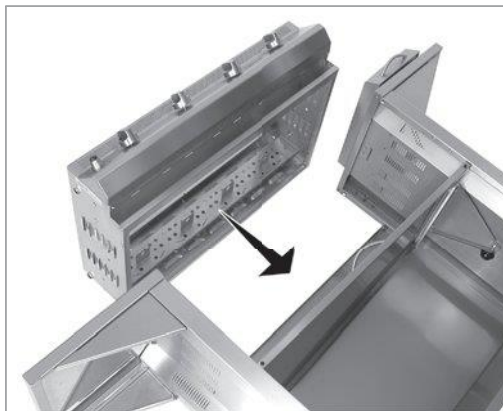

# 14

## YOU WILL NEED

2 x 10mm screws



Screw the cylinder bracket to the right side panel.

Ensure the top of the cylinder bracket passes through the slot in the side panel so that the screw passes through the side panel before it secures the bracket.

\*Not required for Natural Gas Units.

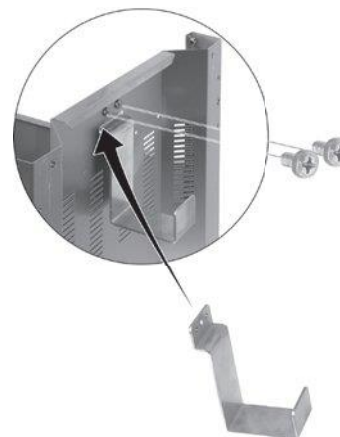

**Finally, tighten up all screws and your assembly is complete.**

ABM-TROLINTL-0808

Manufactured by  
Australian Barbeque Manufacturers  
6/9 Fitzpatrick St  
Revesby NSW 2212  
ph (02) 9773-6245