

**NOTE:** Not to be placed on heat sensitive benchtop materials. Benchtops to be in non-combustible materials not vulnerable to distortion or colour shift under heat.

Vented Base is recommended for benchtop mounting of all Wood-Fired Pizza Ovens

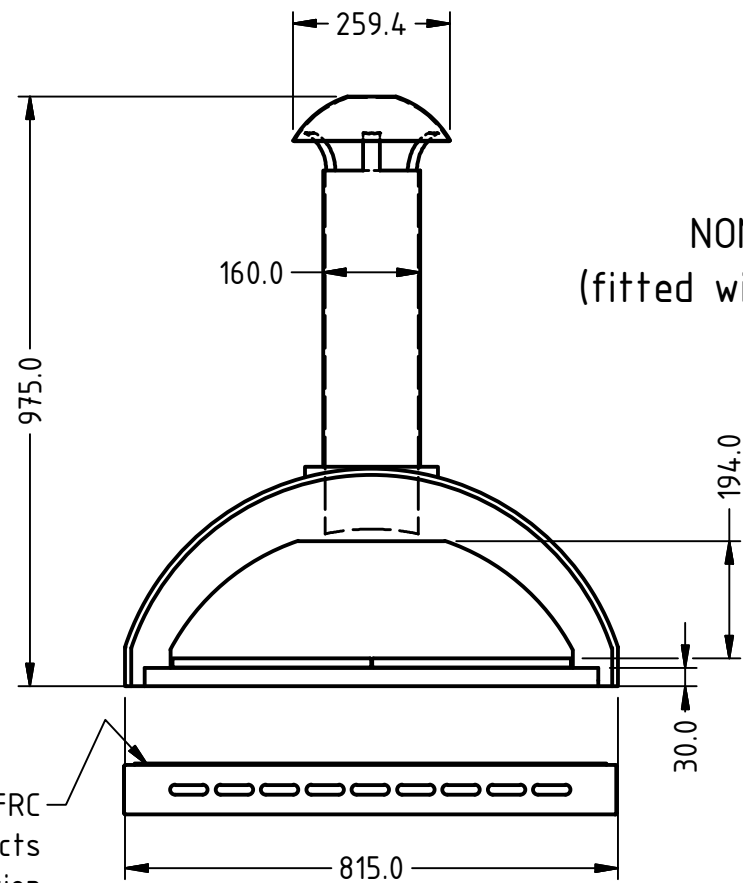
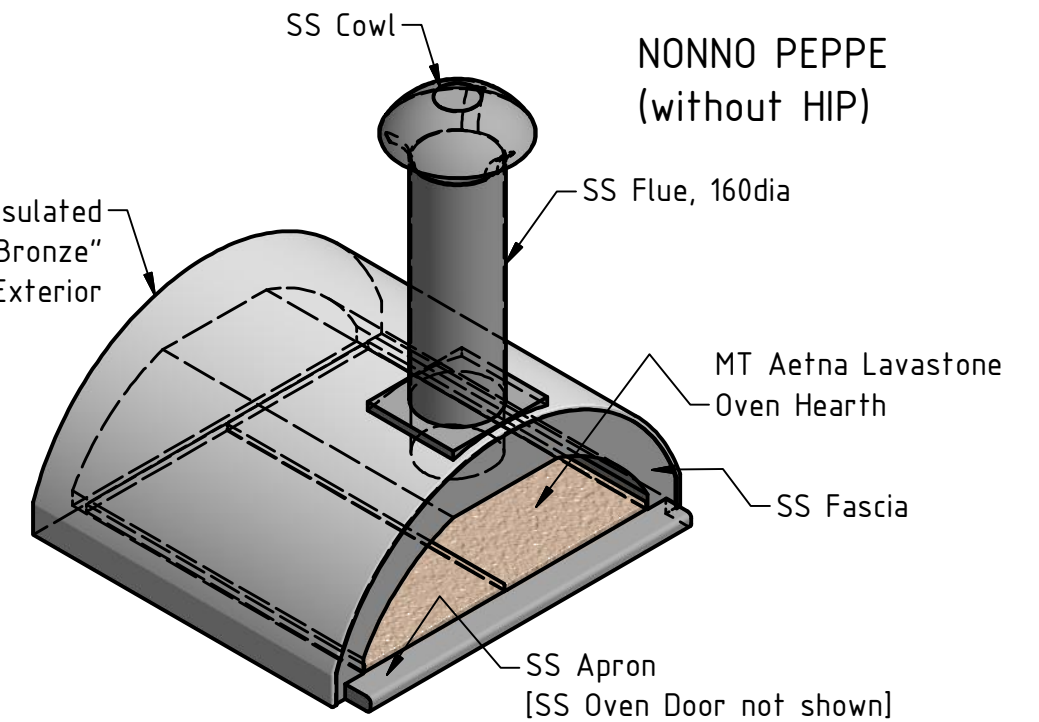

NONNO PEPPE  
(fitted with Vented Base)

Ventilated SS/FRC Vented Base [acts as Heat Isolation Platform]

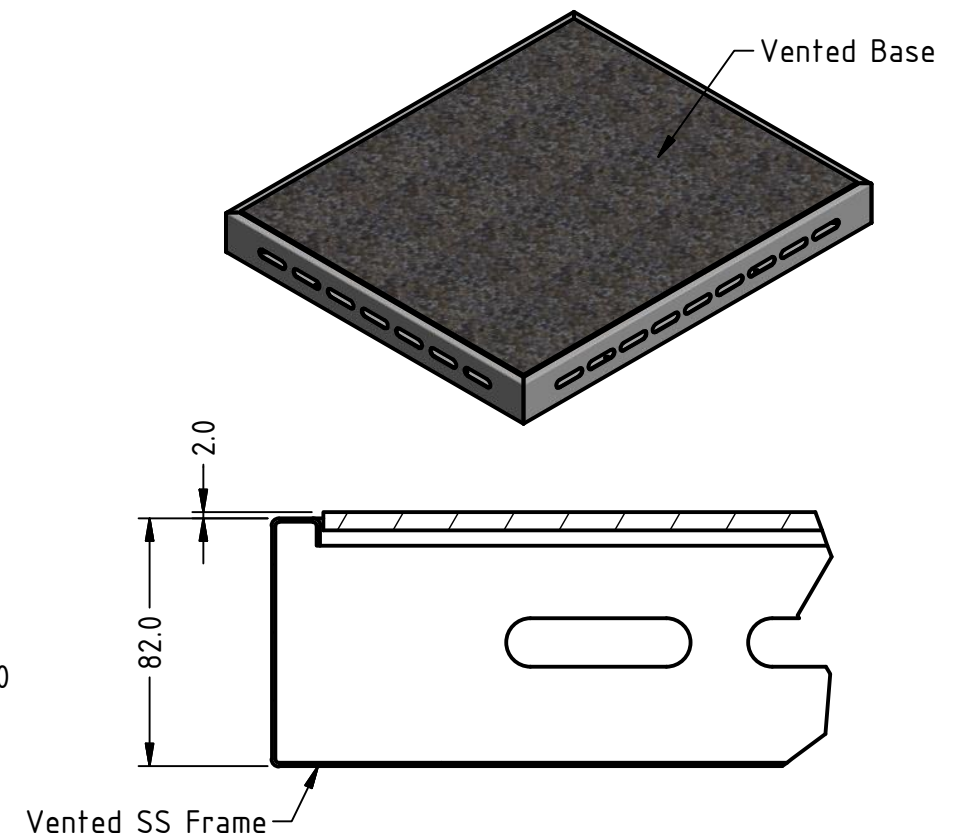
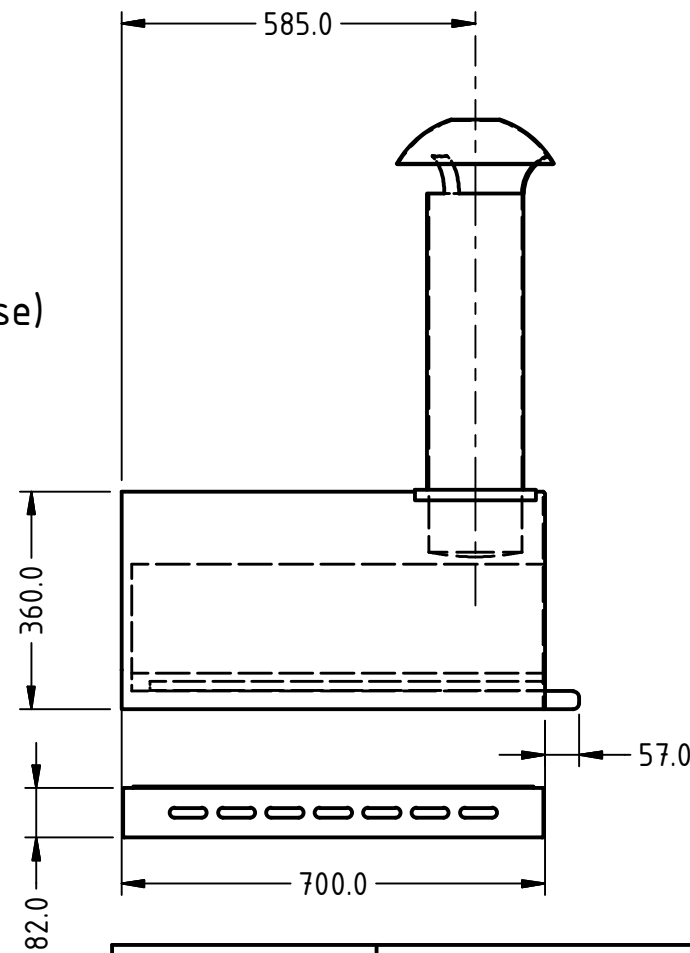

Part Number:	EP-01 ASSY	Material:
Part Description:	EP-01 Nonno Pepe Pizza Oven Assembly	Thickness:
Product Group:	OTI	Surface Finish:
Job Number:	Stock Assy	Colour:

	GEN. TOL	
	Linear	Angular
X	± 1.0	± 2°
X.X	± 0.6	± 1°
X.XX	± 0.25	± 0.5°

Authorised By:		Date:	
Designed By:	Blair Boaden	Date:	
Approved By:		Date:	

